

User Manual

Solar Pump Inverter 3000W-22000W

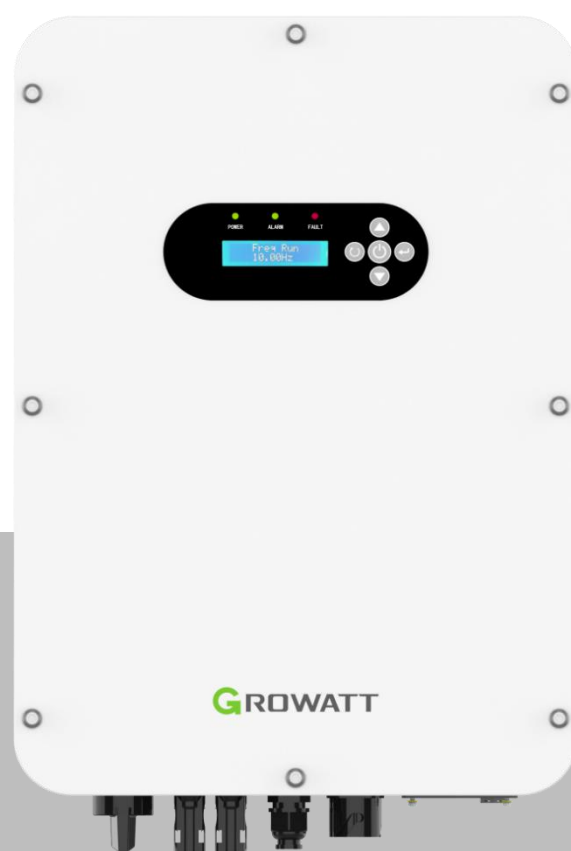

Table Of Contents

Information on this Manual	1
Validity.....	1
Scope	1
Target Group.....	1
Safety Instructions.....	1
Symbols	2
Introduction	3
Features.....	3
Product Overview	4
INSTALLATION	5
Unpacking and Inspection	5
Mounting the Unit	5
Wiring Introduction	7
Terminal Introduction	7
Assemble DC Connector	8
Assemble AC Connector	8
Wiring of Water Level Sensor	9
Assemble Sensor connector.....	10
Recommended Diameter of Wire	11
OPERATION	12
Display Panel.....	12
LCD Display Information	13
Debugging guidance	14
Parameters Setting	16
Troubleshooting	20
Specifications	23

Information on this Manual

Validity

This manual is valid for the following devices:

- ▶ Three phase 380V solar pump inverter, 3000W~22000W

Scope

This manual describes the assembly, installation, operation and troubleshooting of this unit. Please read this manual carefully before installations and operations.

Target Group

This document is intended for qualified persons and end users. Tasks that do not require any particular qualification can also be performed by end users. Qualified persons must have the following skills:

- ▶ Knowledge of how a pump inverter works and is operated
- ▶ Training in how to deal with the dangers and risks associated with installing and using electrical devices and installations
- ▶ Training in the installation and commissioning of electrical devices and installations
- ▶ Knowledge of the applicable standards and directives
- ▶ Knowledge of and compliance with this document and all safety information

Safety Instructions

WARNING: This chapter contains important safety and operating instructions. Read and keep this manual for future reference.

Inspection



If missing components or damaged inverter is found after receiving, please do NOT install or operate it. Otherwise, it may cause human injury or equipment damage.

Installation



1. Before installation, please make sure if the voltage range of PV panel meets the requirement.
2. Check if all wires are firmly connected without short circuit. Otherwise, it will cause equipment damage.
3. Do NOT install this inverter under direct sunlight because high temperature may cause equipment damage.
4. Please install the inverter away from inflammable and explosive objectives. Please ensure no liquid can enter the inverter.
5. Please install the inverter on metal non-combustible surface.



1. **CAUTION!!** Only qualified personnel can install and operate this inverter.
2. To reduce risk of electric shock, disconnect power source before making wire connection. Otherwise, it may cause electrical shock.
3. To reduce risk of electric shock, NEVER touch any terminals on electric circuits.
4. If connection cable between inverter and water pump is more than 50m, please be sure to install a three-phase AC reactor. Inductance value for each phase is about 1mH. Otherwise, water pump would be easily to be damaged.

Operation









1. Only after wire connection is complete and put cover back to the inverter, it's Enter to do commissioning. Otherwise, it will cause electric shock
2. If sunlight is sufficient but little water is pumped, maybe the wires on motor connection are reversely connected. Please reverse any two wires of them.
3. When testing water pump, be sure to install water pump at appropriate water level. Never allow water pump in dry running. Otherwise, the inverter will activate protection.

Maintenance



1. Only qualified personnel can maintain, repair, inspect the inverter and replace any components.
2. It may still contain energy after disconnecting power source within 5 minutes. Only service after the bus voltage is within safe range.

Symbols

	Grounding Wire of Equipment
	AC Value
	DC Value
	Phase
	Before operating inverter, please read the instruction.
 <u>5 minutes</u>	In order to avoid electric shock, break off machine with PV terminal and AC terminal for at least 5 minutes, then contact the wire of machine output terminal and input terminal
	Warning: when machine works, the temperature of metal shell may be very high.

Introduction

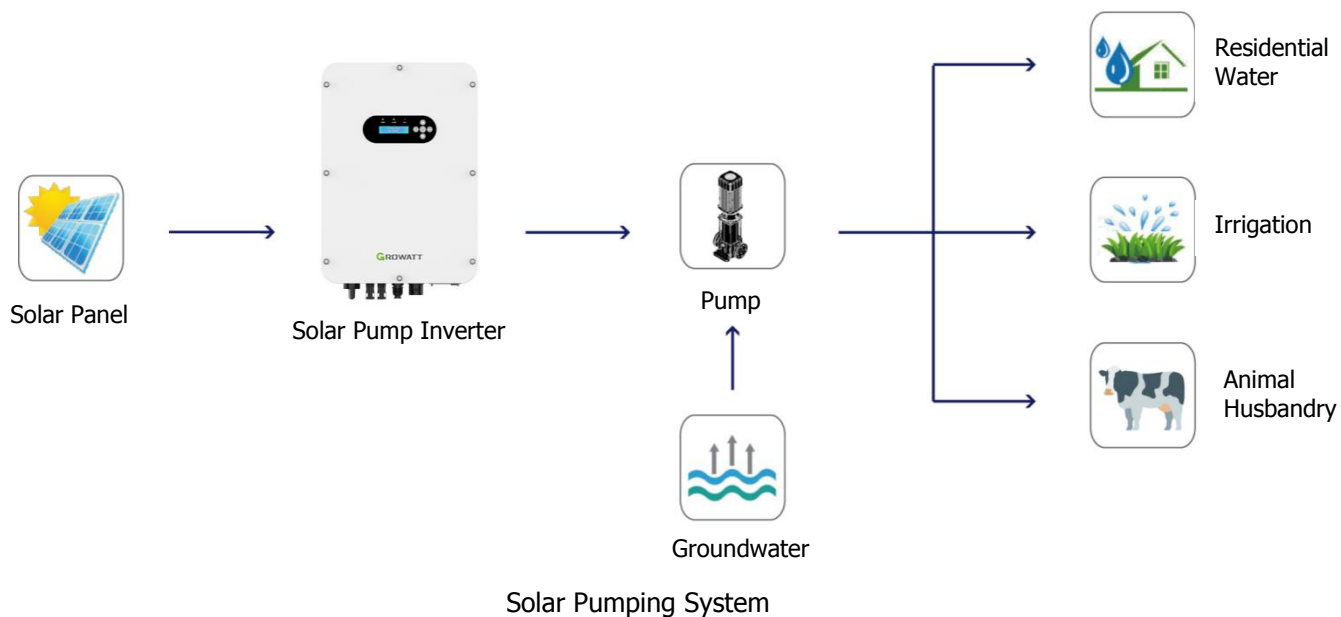

This is a solar pump inverter which allows power to be switched from the DC power obtained from solar panels to the AC power needed to control the pump.

This series solar pump inverters are built-in with MPPT solar charger to maximize solar power. The inverter is suitable for submersible pumps, ground pumps, swimming pool pumps and other pumps using three phase asynchronous motors.

Features

- ▶ Rated power 3KW to 22KW
- ▶ Inbuilt MPPT solar controller
- ▶ IP65 protection level
- ▶ Built-in full protection and self-diagnosis
- ▶ Soft start function
- ▶ Comprehensive LCD and LEDs display real-time system status
- ▶ Remote monitoring through GPRS /WIFI(optional)

Product Overview

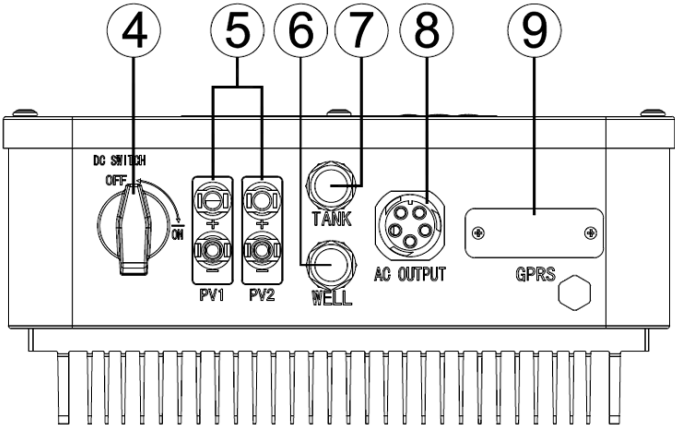
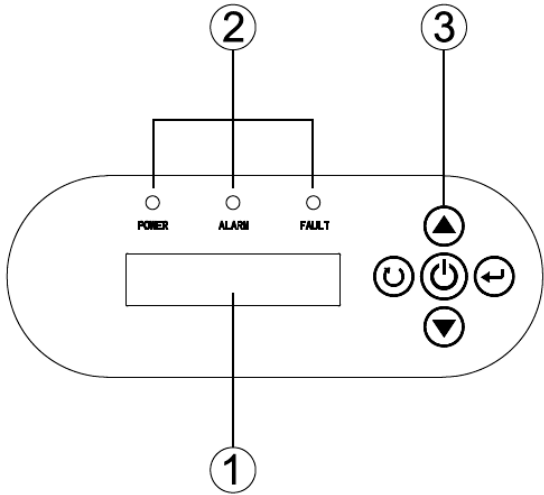
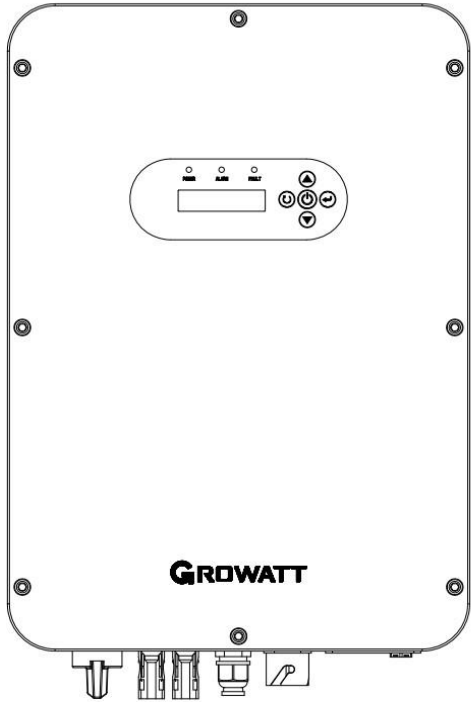

1. LCD display
2. LED indicators
3. Function buttons
4. DC switch
5. PV input
6. Water level sensor port --WELL
7. Water level sensor port –TANK
8. AC output
9. GPRS/WIFI communication port

INSTALLATION

Unpacking and Inspection

Before installation, please inspect the unit. Be sure that nothing inside the package is damaged. You should have received the following items inside of package:

- The unit x 1
- User manual x 1

Mounting the Unit

Consider the following points before selecting where to install:

- Do not mount the inverter on flammable construction materials.
- Mount on a solid metal surface.
- Avoid direct sunlight. Be sure the environment is shady and cool.
- Be sure to install the inverter into a box with waterproof and dustproof.
- Install this inverter at eye level in order to allow the LCD display to be read at all times.
- The recommended installation position is to be adhered to the wall vertically.
- Be sure to keep other objects and surfaces as shown in the diagram to guarantee sufficient heat dissipation and to have enough space for removing wires.

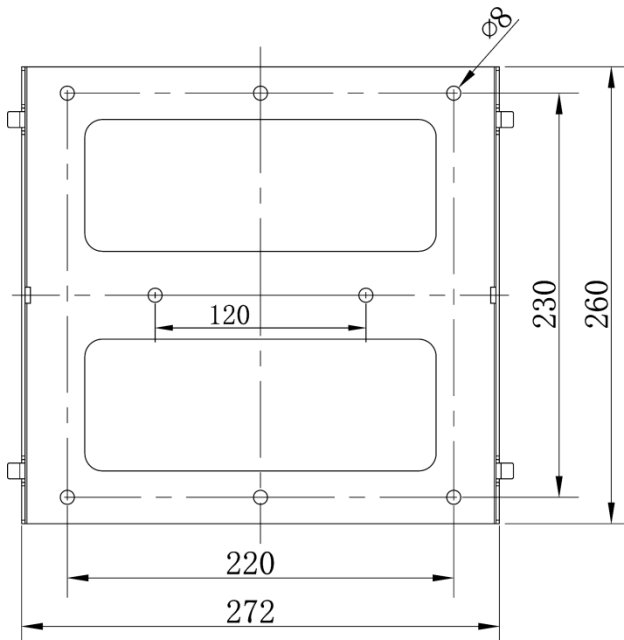
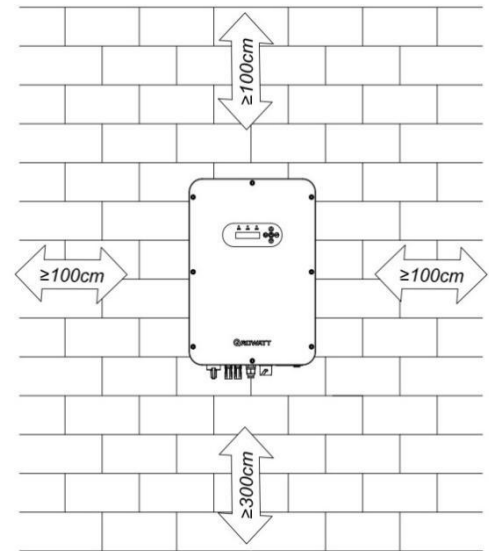

3 phase 380V 3kw-5.5kw

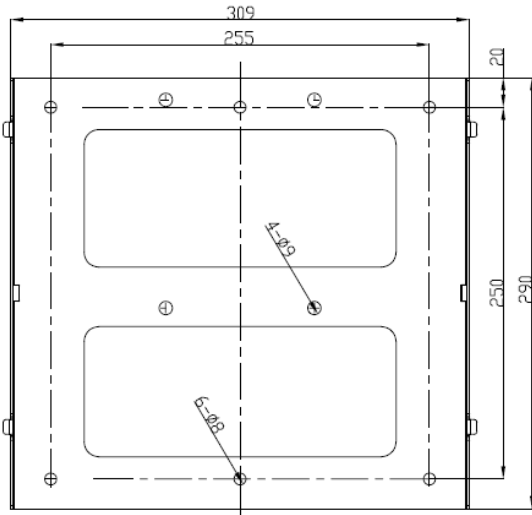

3 phase 380V 7.5kw-11kw

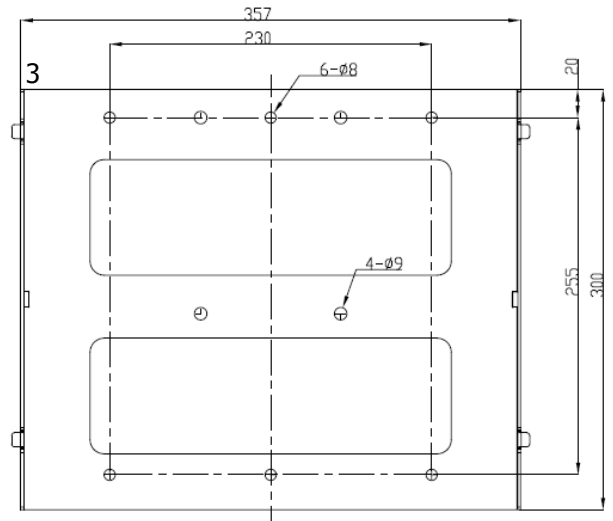

3 phase 380v 13kw-22kw



SUITABLE FOR MOUNTING ON CONCRETE OR OTHER NON-COMBUSTIBLE SURFACE ONLY.

Install Safety Nut

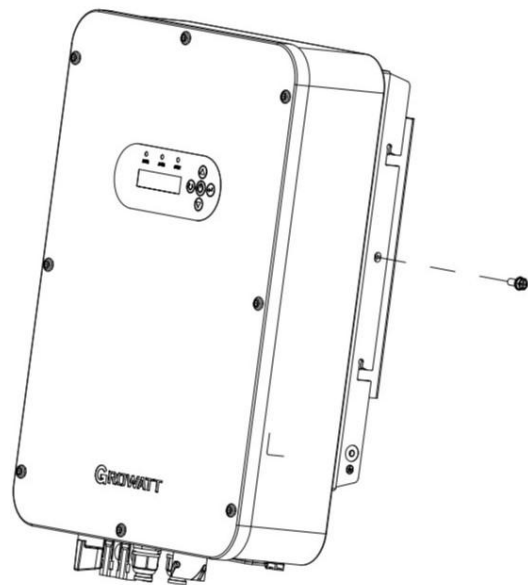
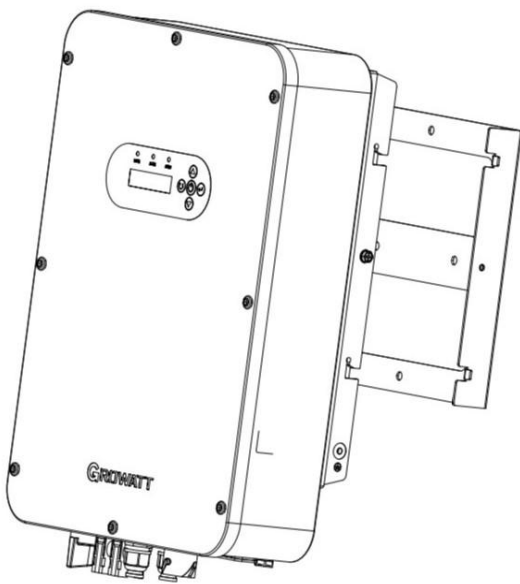

Wiring Introduction

There is DC switch, water level sensor connection terminal, GPRS (optional), and AC output terminal.

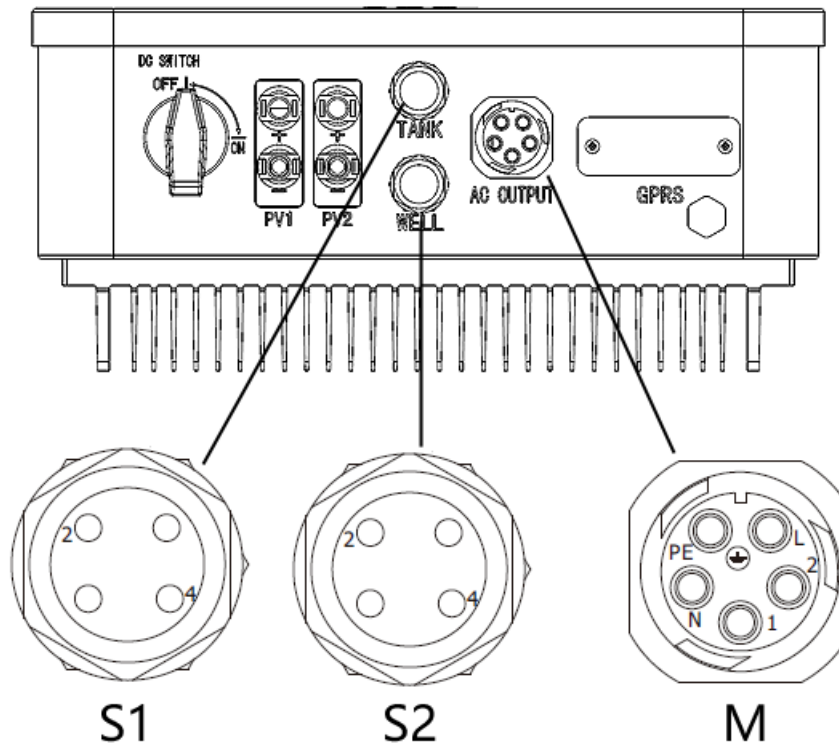

Terminal Introduction

Socket	Terminal Introduction	Wiring Introduction
DC Input	PV+	Connect with the positive pole of solar array
	PV-	Connect with the negative pole of solar array
AC Output	M-1	Connect with motor U phase
	M-2	Connect with motor V phase
	M-L	Connect with motor W phase
	M-PE	Connect with protective ground wire
Water Level Sensor Input (Switch Value)	S1	Signa2 of water tank
		Signa4 of water tank
	S2	Signa2 of well
		Signa4 of well



Warning: The places of input sockets of DC positive pole and negative pole of different models are different.



Warning: The signal marshalling sequence of AC output sockets of different models are different.

Assemble DC Connector

Strip the cable 6-8mm, then connect the bare wire core into core tube of connector.



Crimp contact barrel by using a hex crimping die. Put the contact barrel with striped cable in the corresponding crimping notch and crimp the contact. Insert the core tube into slot of connection until hear the sound indicating fit in place.

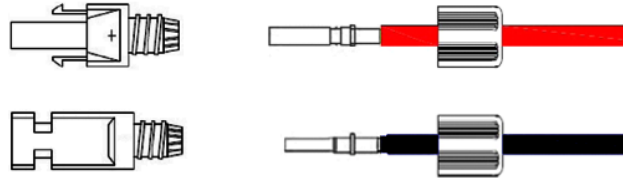

Tighten the nuts to finish the wiring.

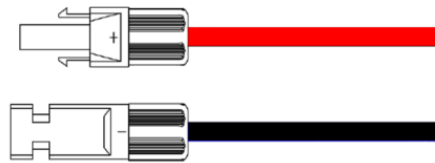

Warning: Risk of electric shock! Before shifting solar panel, disconnect the pump inverter AC and DC. Besides, allow 5-minute internal capacitance discharging.

Assemble AC Connector

AC connector gets connection with the pump through 4 wires (U wire, V wire, W wire and PE wire)

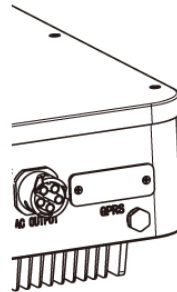

Remove the parts of the AC connection plug from the accessory bag. Guide the pressure screw sealing right, threaded sleeve over the AC cable.

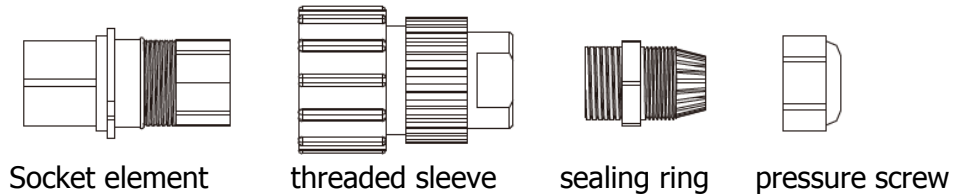

Insert the stripped and bared conductors U, V, W, PE in to screw terminals with sign U, V, W, PE on the socket element and tighten the screws.

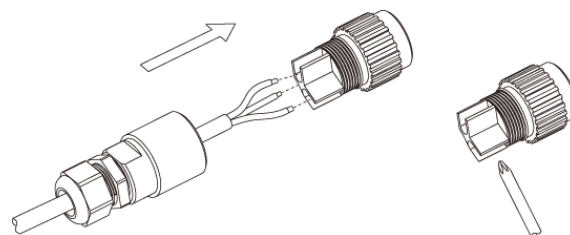

Connect the conductors

Push the threaded sleeve in to the socket element. Screw the pressure screw tightly onto the threaded sleeve.

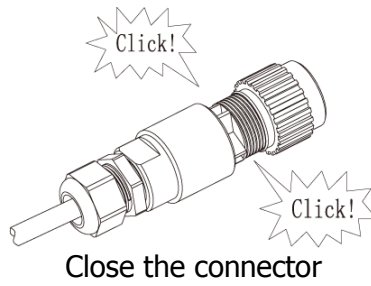

Insert the AC connection plug into the AC connection receptacle on the inverter.

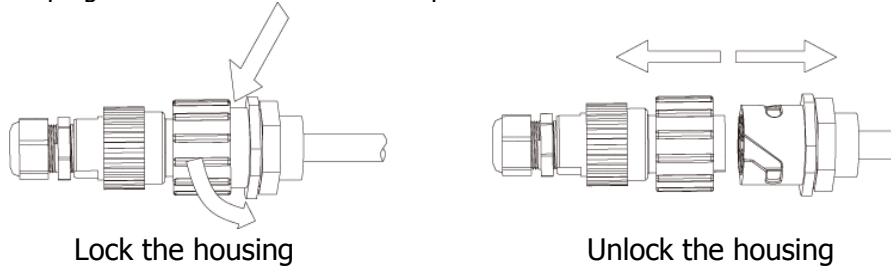

Wiring of Water Level Sensor

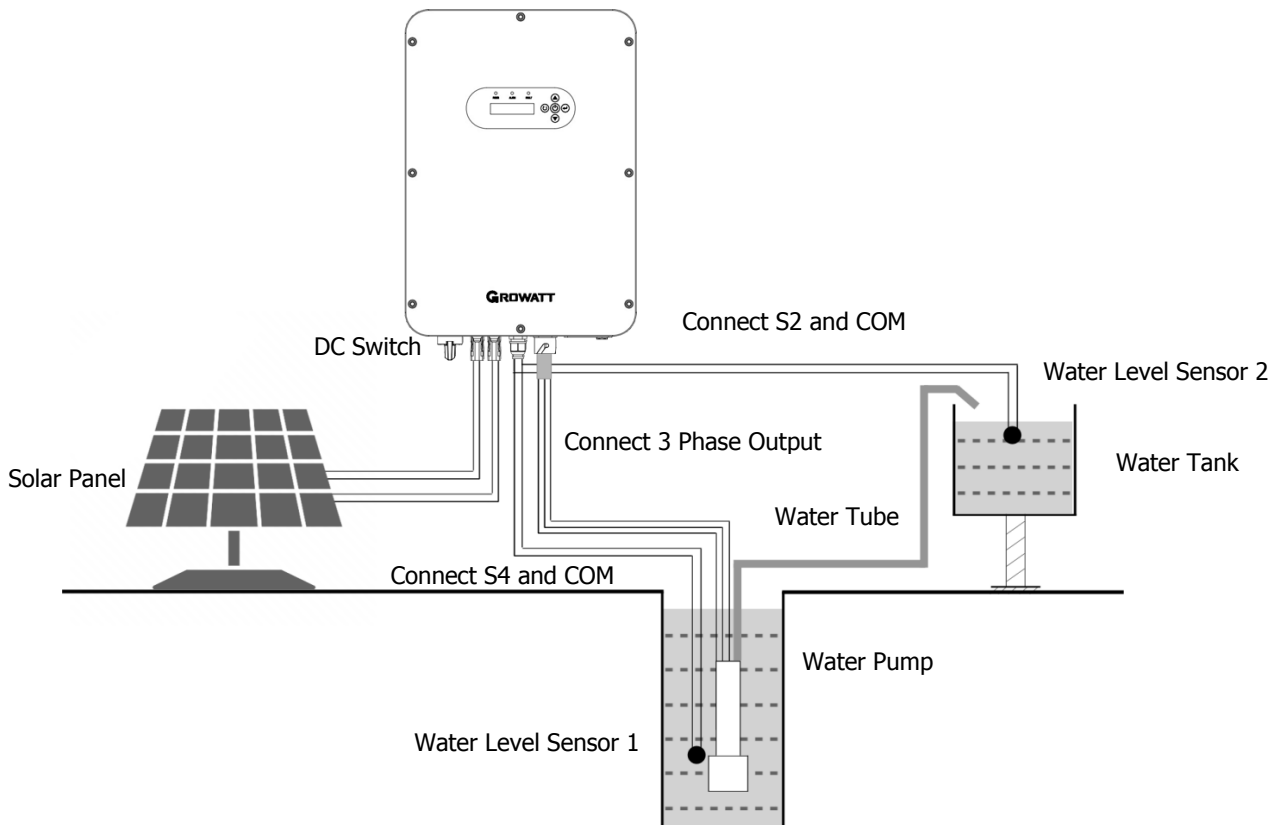

Assemble Sensor connector

Insert the stripped and bared conductors 2,4 in to screw terminals signal 2,4 on the socket element and tighten the screws.

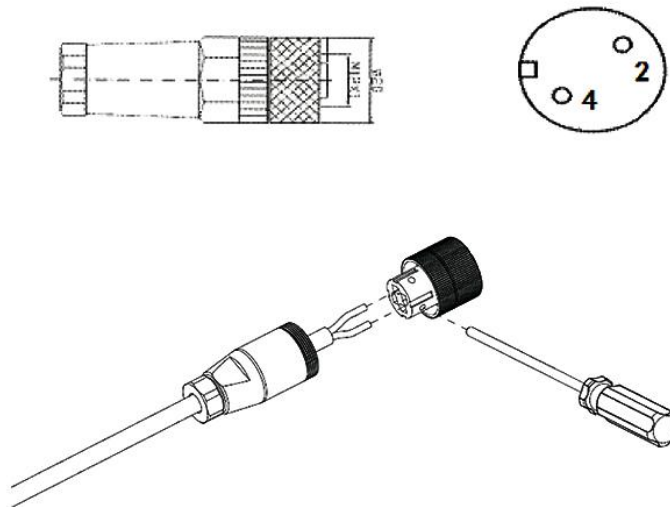

Push the threaded sleeve in to the socket element. Screw the pressure screw tightly onto the threaded sleeve.

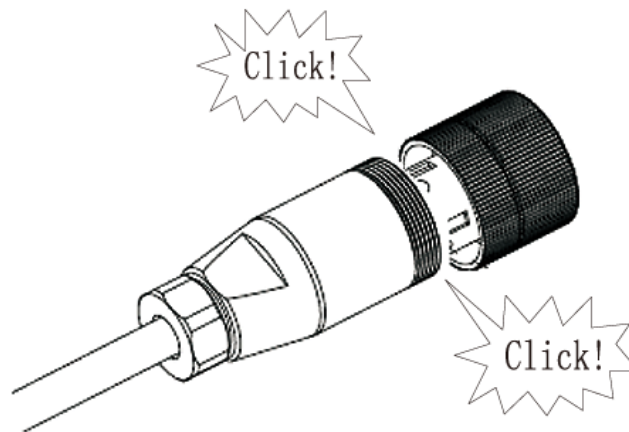

! Notice: connect water level sensor 1 and detect water shortage. Respectively connect two signal lines of sensor with S4 and COM of I/O circuit board. When water level sensor 1 detects that the water level of well is lower than the level set by sensor, the pump inverter will delay for 60s, then turn off output protection pump. The water level recovers. Wait for 600s, then the pump inverter re-works normally.

! Notice: connect water level sensor 2 to detect whether water is full. Connect two signal lines of sensor with S2 and COM. When water level sensor 2 detects that the water level of water tank exceeds the level set by sensor, the pump inverter delays for 60s and turns off output; when water level is lower than set level, wait for 120s, then pump inverter re-starts to work normally.

Recommended Diameter of Wire

Model	Recommended output current(A)	Output voltage(V)	length≤ 30m	length≤ 60m	length≤ 90m	length≤ 120m	length≤ 150m	length≤ 180m	length≤ 210m
SPI 3000	8	3PH 380V	1.5	2.5	2.5	6	6	6	6
SPI 4000	10	3PH 380V	1.5	2.5	2.5	6	6	6	6
SPI 5500	13	3PH 380V	2.5	2.5	4	6	6	6	6
SPI 7500	18	3PH 380V	2.5	2.5	4	6	6	10	10
SPI 9200	21	3PH 380V	4	4	4	6	10	10	10
SPI 11000	24	3PH 380V	4	4	6	10	10	10	16
SPI 13000	28	3PH 380V	6	6	6	10	10	10	10
SPI 15000	30	3PH 380V	6	6	6	10	10	16	16
SPI 18000	39	3PH 380V	6	6	10	10	16	16	25
SPI 22000	45	3PH 380V	10	10	10	16	16	25	25
Units: mm ²									



Notice: The environment temperature for the above recommended wire dimension should $\leq 50^{\circ}\text{C}$.







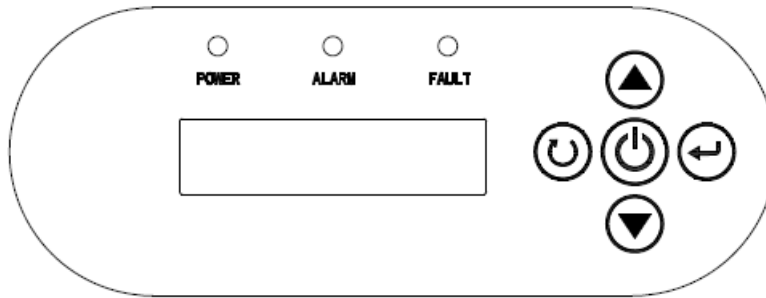

Notice: Large-power wall-mounted model uses multiple-channel DC input. The dimension of DC wire of each channel shall be selected according to the above table.

OPERATION

Display Panel

Solar pump inverter uses LCD operation panel. The operation panel is shown in the figure, including 3 LED lights, LCD display and 5 keys.



Indicator and Key	Name	Function Introduction	
POWER	System running indicator	Green	LED on, inverter is running
ALARM	Warning indicator	Yellow	LED on, warning, or LED flashing in auto operation mode
FAULT	Failure indicator	Red	LED on, system failure
	Operation / Stop Key	1. Press for a short time, then the inverter starts control; 2. Press for 2s, then inverter stops control.	
	Confirm / Programming Key	1. Press for a short time to enter programming mode. After altering parameter, "press for a short time" to confirm the alteration 2. Press for 2s to enter the programming menu.	
	Increment Key	1. When control parameter displays state, increase parameter number or parameter value; 2. When operation displays data state, according to operation mode, increase output frequency or display current operation data.	
	Decrement Key	1. When control parameter displays state, press for a short time to decrease parameter number or parameter value. 2. When operation shows data state, according to operation mode, decrease output frequency or display current operation data.	
	Return Key	Return the initial display.	

LCD Display Information

The LCD display information includes operation data, control parameters, and historical parameters. The information on the display will be switched in turns by pressing UP/DOWN key. The selectable information will be switched as below.

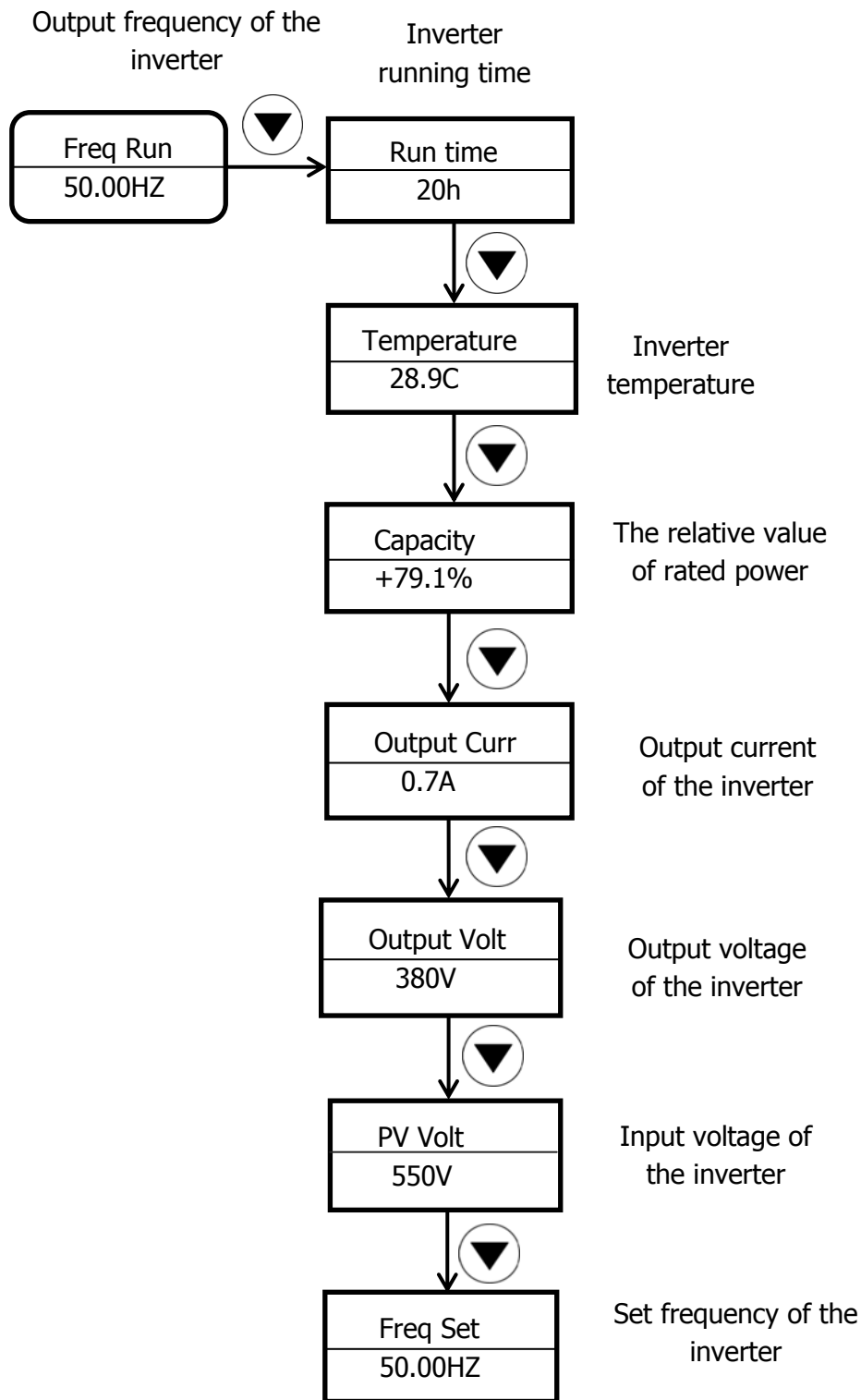

Debugging guidance

Before setting the parameters, please make sure all the wiring is correct.

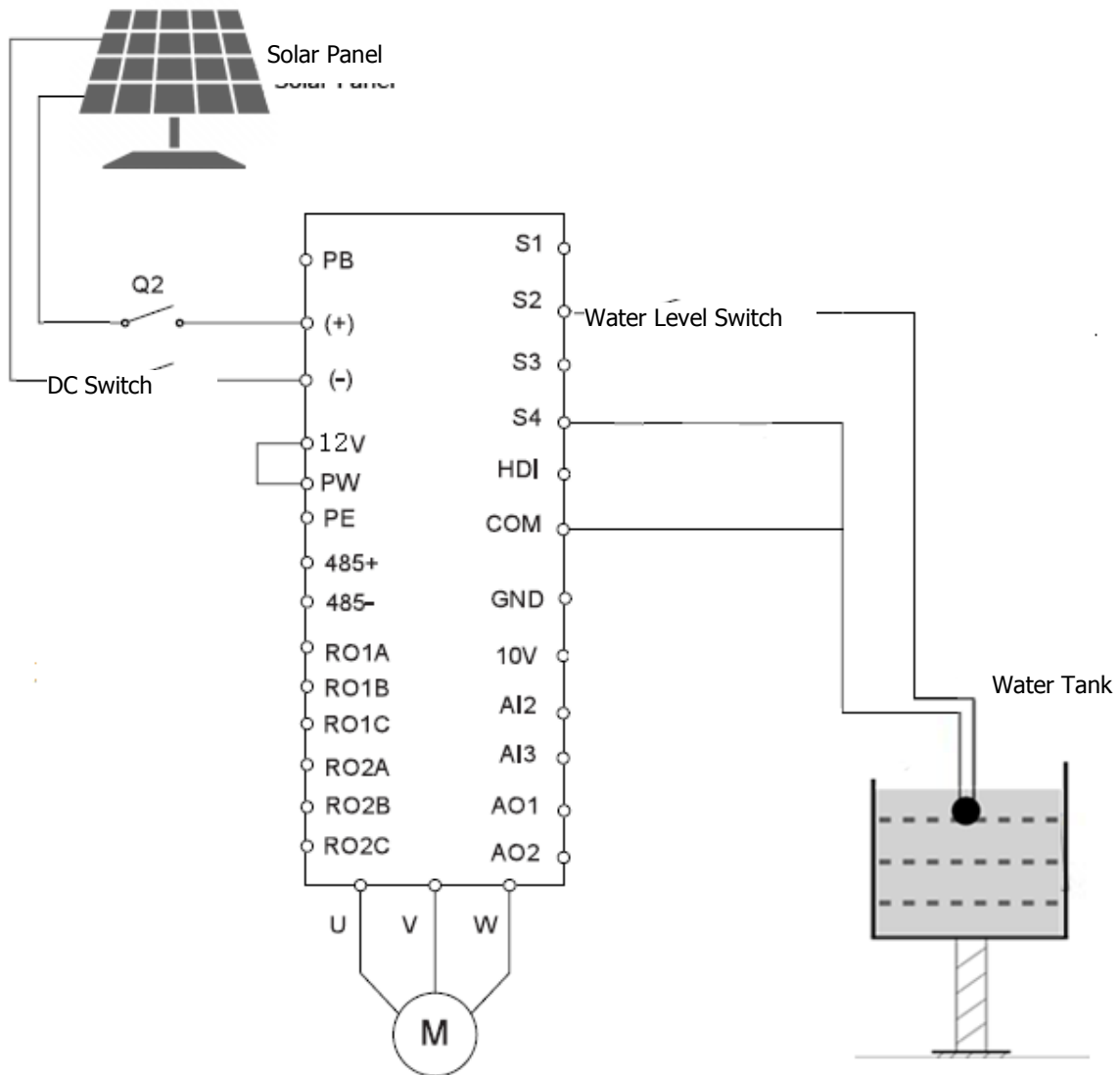

- Setting P00.01=0. Manual operation mode settings.
- Set water pump nameplate parameters: P02.01 motor rated power value; P02.02 motor rated power value; P02.04 motor rated voltage value; P02.05 motor rated current value.
- Water output test of pump
Click the run button to observe the running frequency and water output. Under the normal strong light condition, if the working frequency is low or the water volume is small, it indicates that the motor line may be connected reversely, so it is necessary to set function code P00.13=1 or exchange the wiring of two motor lines.
- After finishing parameter setting of water pump, set P00.01=1. The operation code channel is altered as original automatic mode instruction.

Notice: If the inverter fails, set P00.18 to restore the factory settings.

Parameters Setting

1. Work Mode Setting

The inverter includes three work modes: manual work mode, fully-automatic terminal work mode, GPRS work mode (optional). The default mode is fully-automatic terminal work mode.

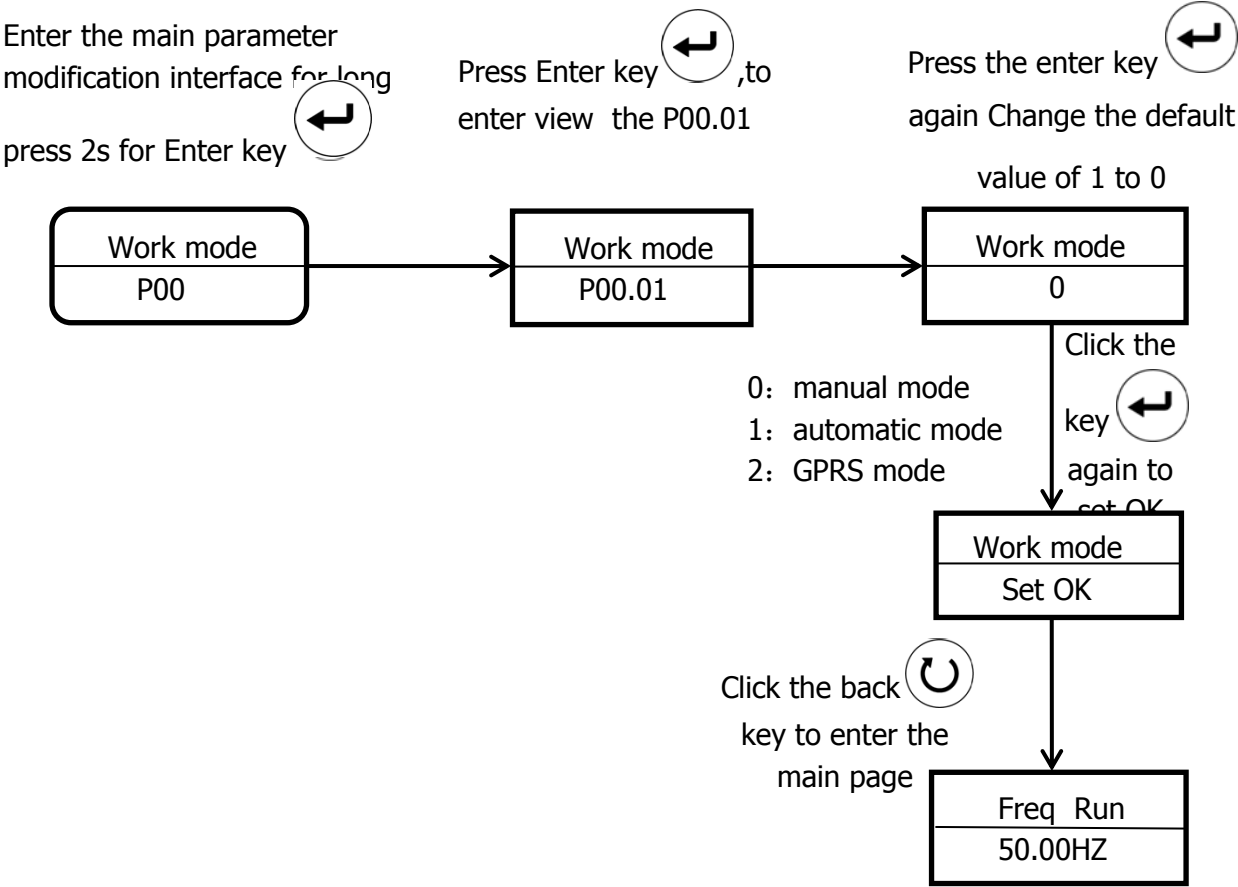

2. Parameter Setting (Example)

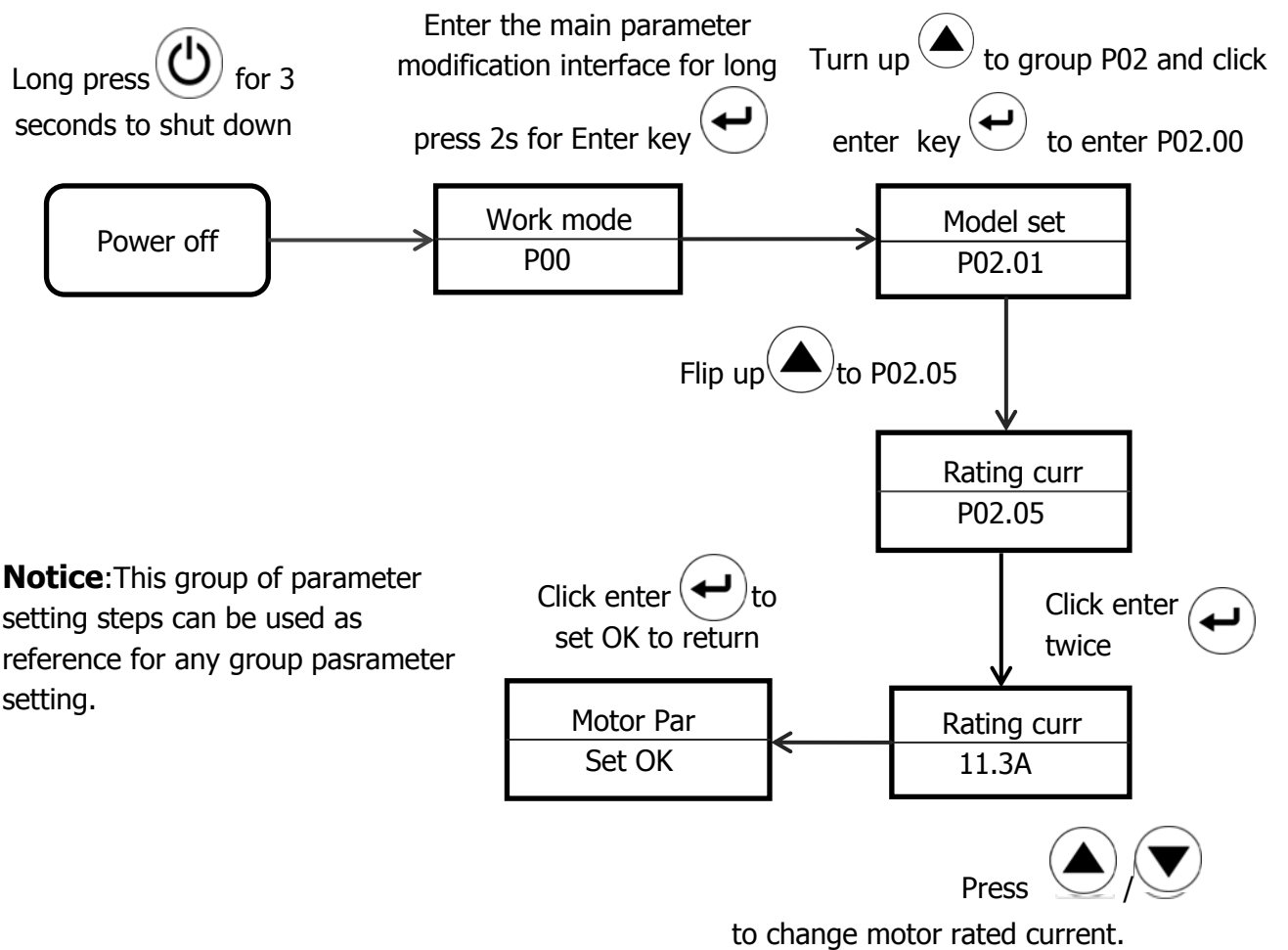



3. Factory Data Reset

Long press  for 3seconds to shut down

Enter the main parameter modification interface for log press 2s for Enter key 

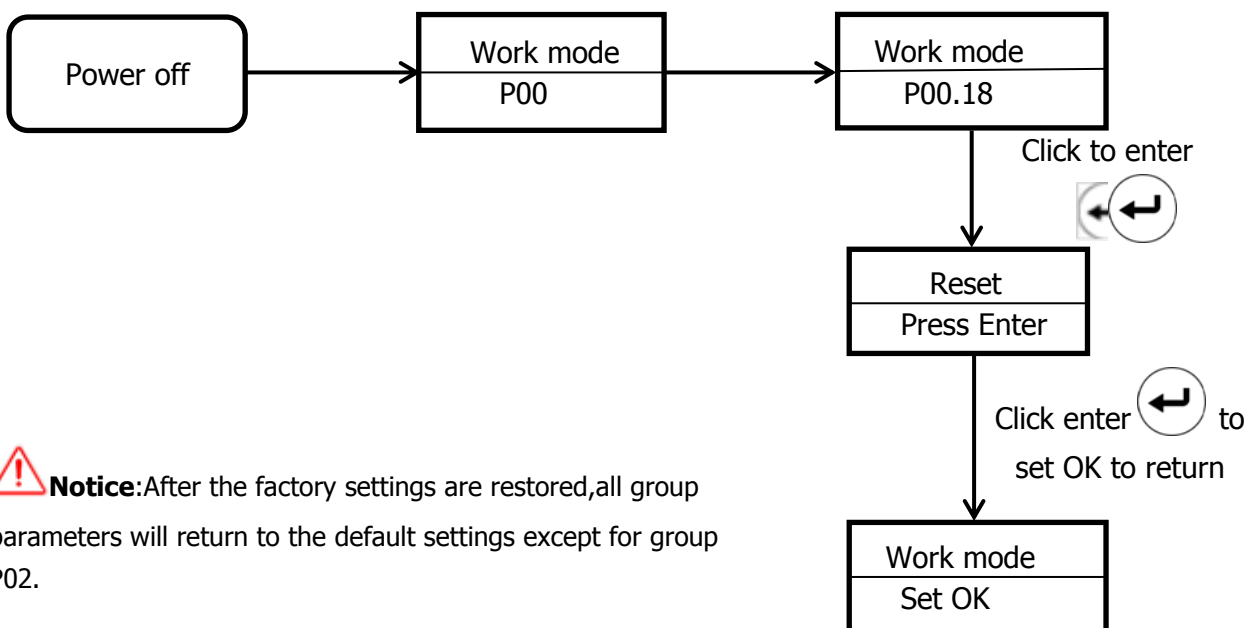
Flip up  to P00.18



 Notice: The set value of the parameter cannot be modified on the running state. If inverter is in auto mode, but you need to set value of the parameter. First setting P00.01=0, manual operation mode settings, press  for 2s, then inverter stops control. then you can set the P00~P15 group of function parameter.

 Warning: Do not change parameters at random, otherwise the system might not work normally.

Function Parameters

SN	Name	Scope	Introduction	Default Value
P00.01	Run commamd model	0~2	0: manual operation NOTE:When set P00 and P02 paramaters,first must set manual operation power off the inverter, P15 not need. 1: auto operation mode 2: communication operation mode	1
P00.03	MAX. Output frequency	P00.04~400.00Hz	The paramater is used to set the maximum output frequency of the inverter	50.00Hz

P00.04	Upper limit of the running frequency	P00.05~ P00.03	The parameter is the upper limit of the output frequency of the inverter which is lower than or equal the maximum frequency	50.00Hz
P00.05	Lower limit of the running frequency	0.00Hz~ P00.04	If the solar energy is not sufficient to power the motor, inverter will drop frequency running. The inverter will stop run when the running frequency lower than the lower limit frequency	0Hz
P00.13	Set direction	0~2	0: The inverter runs in the forward direction 1: The inverter runs in the reverse direction 2: Forbid to run in reverse direction	0
P00.18	Function restore parameter	0~1	0: No operation 1: Restore the default value	0
P01.08	Stop mode	0~1	0: Decelerate to stop 1: Coast to stop	1
P02.01	Rated power of asynchronous motor	0.1~ 3000.0kw	Set this parameter according to rated power on the pump nameplate NOTE: when resetting the rated power of the motor(P02.01), you can initialize the motor parameter of (P02.02~P02.05)	Model confirmation
P02.02	Rated frequency of asynchronous motor	0.01Hz ~ P00.03	Set this parameter according to rated frequency on the pump nameplate	50.00Hz
P02.04	Rated voltage of asynchronous motor	0 ~ 1200V	Set this parameter according to rated voltage on the pump nameplate	Model confirmation
P02.05	Rated current of asynchronous motor	0.8 ~ 6000A	Set this parameter according to rated current on the pump nameplate	Model confirmation
P02.27	Motor overload protection factor	20.0%~120.0%	The pump motor over-load protection factor when over-load, please refer to the rated current of motor to set this parameter.	100.0%
P15.00	PV Inverter Selection	0: Disable 1: Enabled	0: means the function is invalid 1: means the MPPT function is enabled	1
P15.04	PID Max. Output Frequency	P15.05~100.0%	P15.05~100.0%(100%correspongs P00.03) P15.04 is used to limit the Max. value of target frequency	100.0%
P15.05	PID Min. Output Frequency	0.0%~100.0%	0.0%~ P15.04(100%correspongs P00.03) P15.04 is used to limit the Min. value of target frequency	0.0%
P15.13	Delay Time of Dry-Water	0~10000S	Delay Time setting of dry-water, under auto dry run mode or water sensor mode	60S

P15.14	Wake-up Delay Time of Dry-Water	0~10000S	Dry out recovery time, under auto dry run mode or water sensor mode	600S
P15.15	Automatic Dry run protection	0.0~100.0%	0.0%:No automatic dry run protection 0.1%~100.0%:It is determined by P15.15 100% corresponds to the rated motor current. If the running frequency >30Hz,and the current corresponding to the current frequency is less than P15.15, after the time set by P15.13, the inverter will stop run,otherwise,it will operate normally. After the time set by P15.14, the inverter will reset.	0.0%
P15.16	Delay Time of Full-Water	0.0~1000.0S	Delay Time setting of Full-water, under water sensor mode	60.0S
P15.18	Reset Delay of Full-Water	0.0~1000.0S	Dry out recovery time, under water sensor mode	120.0S
P15.19	Frequency of Weak Light	0.00~50.00Hz	If the output frequency is less than the frequency of Weak Light, it will stop run.	5.00Hz
P15.20	Delay Time of Weak Light	0.0~3600.0S	Delay Time of weak light, after the time set by P15.20, the inverter will stop run.	100.0S
F15.21	Reset Delay of Weak Light	0.0~3600.0S	Reset Delay of weak light,after the time set by P15.21, the inverter will reset	300.0S

Troubleshooting

The inverter has complete protection. When a failure occurs, the inverter will take protective measures. The general protection is to stop the motor from running and forbid it to restart within a certain period.

Fault Code	Fault type	Possible Reasons	Solution
Power off	No failure	\	\
Inc OVP Dec OVP Const OVP	Overvoltage	1.Input voltage is too high 2.There is large energy feedback	1.Check the voltage of solar array 2.Check if the DEC time of the load is too short or the inverter starts during the rotation of the motor
Bus low	Undervoltage	1.Input voltage is too low; 2.Illumination intensity is too weak	Check the voltage of solar array

Inc OCP Dec OCP const OCP	Overcurrent	1.The load of pump is too large; 2.The voltage of solar array is too low; 3.The motor wiring is too long 4.The power of the inverter is too low 5.The grounding is short circuited or the output is phase loss	1.Replace for a smaller pump; 2.Check voltage of solar array; 3.Shorten the wiring between inverter and motor 4.Select the inverter with a larger power 5. Check if the load is short circuited
Overload Pump	Water pump is overload	1.The motor setting rated current is incorrent 2.Input voltage is too low 3.Improper motor's overload protection threshold 4.Motor block or sudden change of load	1.Reset the rated cueernt of the motor 2.Inspect the input power supply 3.Set proper motor rated current 4.Check the load and adjust torque boost
Overload VF	Inverter is overload	1.Acc time is too short 2.Restart the rotating motor 3.Input voltage is too low 4.the load is too heavy	1.Increase the Acc time 2.Avoid restart after power off 3.Check the power supply 4.Select bigger capacity inverter
IGBT short	Module overcurrent	Output short circuit or grounding module damage	1.Check the wiring 2.Get after-sells support
Inv Overtemp	Module is over-temperature	1.Air flue is blocked 2.Environment temperature is too high	1.Clean air flue or improve ventilation 2.Degree the environment temperature
Rec Overtemp	Module is over-temperature	3.The time of overload runing is too long. 4.Control board abnormal	3.Select a proper motor 4.Ask for support
Phase out loss	Output default phase	Phase loss of U,V,W output (or a serious unbalance in 3phase input)	1.Check the output distribution 2.Check the motor and cable 3.Get after-sells support
Shortcut GND 1	Grounding short circuit	The output line may be connected with ground	Check the wiring
Curr fault	Current detection failure	1.The control board connection is in poor contact 2.The hall component is damaged The magnifying circuit is abnormal 3.The magnifying circuit is abnormal	1.Check the connector and rewire 2.replace the hall component 3.replace the main control panel 4.Get after-sells support
Lack load when set dry-power (P15.15) is not 0.0%	Water pump conducts "dry-operation"	1.Water pump's connection wires are all open circuit. 2.Water sources are lacking of water	1.Check P15.15 parameter 2.Check whether the water pump wiring condition and water pump power meet the requirements of inverter capacity
Lack Water	Water shortage	Water shortage warning	1.If the water empty alarm function is enabled,the device automatically stops after the water empty alarm remains for a certain period of time, and no processing is needed. 2. If the water empty alarm function is not enabled, check whether there are terminals misconnected

Water Full	Water full	Water full warning	<p>1.If the water full alarm function is enabled,the device automatically stops after the water empty alarm remains for a certain period of time, and no processing is needed.</p> <p>2. If the water empty alarm function is not enabled, check whether there are terminals misconnected</p>
Com Fault	Communication failure	Device or circuit damage	<p>Reset</p> <p>Get after-sells support</p>



Warning: Try to find out the failure reason before your try reset. If it can't reset or suffers failure again after reset, please try find out the reason first. Continuously resetting could damage the inverter.

Specifications

Model	Max. DC input voltage (Vdc)	Recommended MPP voltage (Vdc)	Start voltage (Vdc)	Rated output power (W)	Max.AC output current (A)	Output frequency (Hz)	Rated output voltage (Vac)	Dimension (mm)	Weight (kg)
SPI 3000	900	500-680	250	3000	8	0-50/60	3PH 380V	480 x 340 x 155	6
SPI 4000	900	500-680	250	4000	10	0-50/60	3PH 380V	480 x 340 x 155	9
SPI 5500	900	500-680	250	5500	13	0-50/60	3PH 380V	480 x 340 x 155	9
SPI 7500	900	500-680	250	7500	18	0-50/60	3PH 380V	530 x 370 x 165	11
SPI 9200	900	500-680	250	9200	21	0-50/60	3PH 380V	530 x 370 x 165	11
SPI 11000	900	500-680	250	11000	24	0-50/60	3PH 380V	530 x 370 x 165	15
SPI 13000	900	500-680	250	13000	28	0-50/60	3PH 380V	550 x 410 x 178	15
SPI 15000	900	500-680	250	15000	30	0-50/60	3PH 380V	550 x 410 x 178	16
SPI 18000	900	500-680	250	18500	39	0-50/60	3PH 380V	550 x 410 x 178	16
SPI 22000	900	500-680	250	22000	45	0-50/60	3PH 380V	550 x 410 x 178	16